

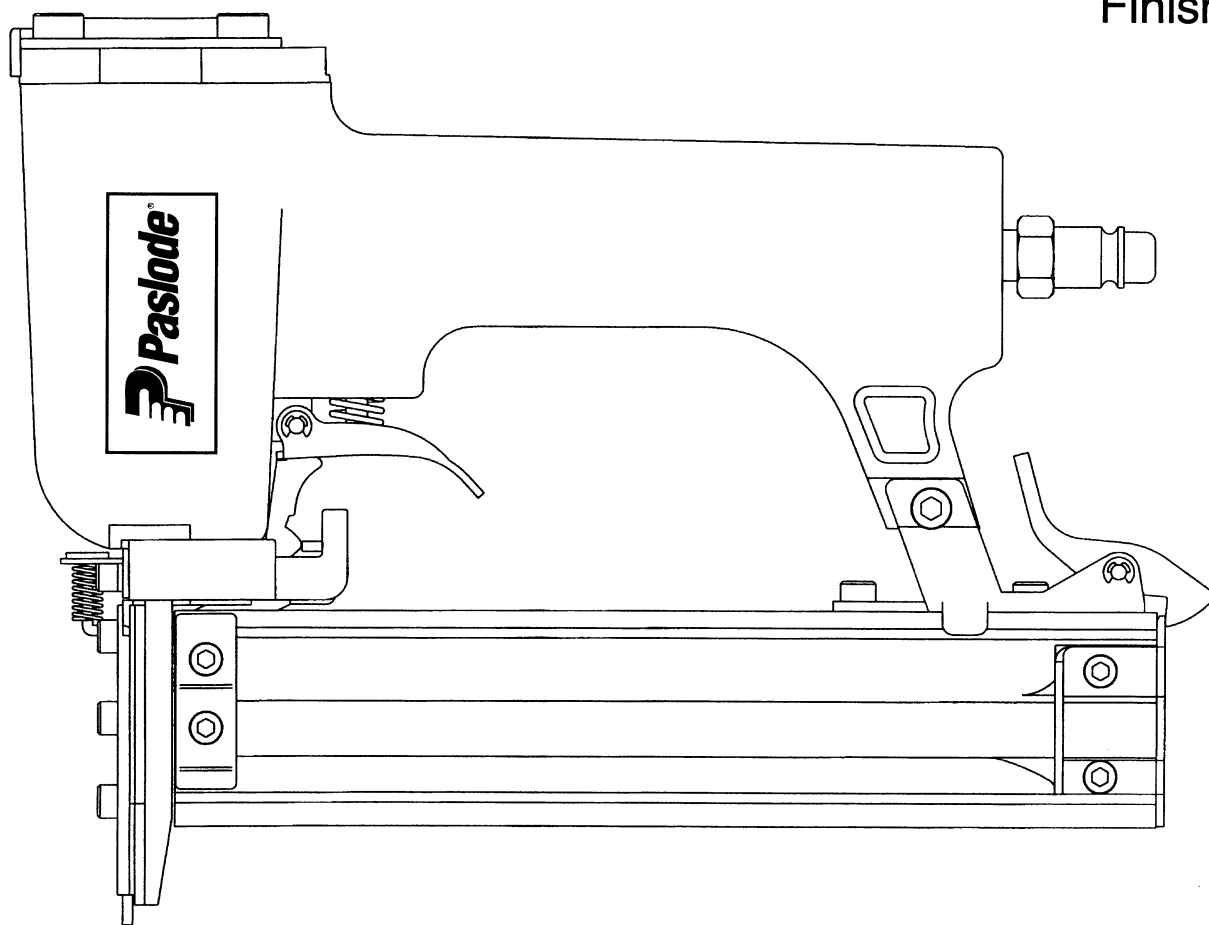

MODEL 2125-F18
Finish Nailer



IMPORTANT!

DO NOT DESTROY

It is the customer's responsibility to have all operators and service personnel read and understand this manual.

**OPERATION MANUAL AND
SCHEMATIC**

INTRODUCTION

The **PASLODE® 2125-F18** finish nailer is a quality-built tool designed for use in residential trim applications. This tool will deliver efficient, dependable performance when used according to the manufactures guidelines. Please study this manual including the safety instructions to fully understand the operation of this tool.

TOOL AND FASTENER SPECIFICATIONS	3
SAFETY INSTRUCTIONS	4
INSTRUCTIONS FOR LOADING	5
EXPLODED VIEW AND SPARE PARTS LIST	6
ACCESSORIES	8

TOOL WARRANTY AND LIMITATIONS

Paslode warrants that newly purchased power fastening tools parts and accessories will be free from defects in material and workmanship (excluding wear parts) for the period shown below, after the date of delivery to the original user.

90-DAY LIMITED WARRANTY

A 90-day warranty will apply to all parts, except those which are specifically covered by an extended warranty.

EXTENDED LIMITED WARRANTY FOR ON SITE CONSTRUCTION APPLICATIONS

A one year warranty will apply to all housing and cap assembly castings. A six month warranty will apply to all magazines parts.

NORMAL WEARING PARTS

The following parts are considered normal wearing parts and are not under warranty:

- Bumper
- Drive Blades
- "O" Rings
- Piston Rings

WARRANTY STATEMENT

Paslode's sole liability hereunder will be to replace any part or accessory which proves to be defective within the specific time period. Any replacement part or accessory provided in accordance with this warranty will carry a warranty for the balance of the period of warranty applicable to the part it replaces.

This warranty is void as to any tool which has been subjected to misuse, abuse, accidental or intentional damage, used with fasteners not meeting Paslode specification, size, or quality, improperly maintained, repaired with other than genuine Paslode replacement parts, damaged in transit or handling, or which, in Paslode's opinion, has been altered or repaired in a way that affects or detracts from the performance of the tool.

PASLODE MAKES NO WARRANTY, EXPRESSED OR IMPLIED, RELATING TO MERCHANTABILITY, FITNESS, OR OTHERWISE, EXCEPT AS STATED ABOVE, and Paslode's liability AS STATED ABOVE AND AS ASSUMED ABOVE is in lieu of all other warranties arising out of, or in connection with, the use and performance of the tool, except to the extent otherwise provided for by applicable law. PASLODE SHALL IN NO EVENT BE LIABLE FOR ANY DIRECT, INDIRECT, OR CONSEQUENTIAL DAMAGES, INCLUDING, BUT NOT LIMITED TO, DAMAGES WHICH MAY ARISE FROM LOSS OF ANTICIPATED PROFITS OR PRODUCTION, SPOILAGE OF MATERIALS, INCREASED COST OF OPERATION, OR OTHERWISE.

Paslode reserves the right to change specifications, equipment, or designs at any time without notice and without incurring obligation.

TOOL AND FASTENER SPECIFICATIONS

TOOL SPECIFICATIONS

MODEL NO.	2125-F18 (Part# 590000)
HEIGHT	7"
WIDTH	2-1/8"
LENGTH	9-1/4"
WEIGHT	2lbs. 10oz.
OPERATING PRESSURE	70 to 100 p.s.i. (4.9 to 7.1kg/cm ²)

FASTENER SPECIFICATIONS

NAIL LENGTH	3/8 - 1-1/4"
SHANK DIAMETER	18 gauge

TOOL AIR FITTINGS:

This tool uses a 1/4" N.P.T. male plug. The inside diameter should be .28" (7mm) or larger. The fitting **must** be capable of discharging tool air pressure when disconnected from the air supply.

OPERATING AIR PRESSURE:

70 to 100 p.s.i. (4.9 to 7.1 kg/cm²). Select the operating air pressure within this range for best tool performance.

DO NOT EXCEED THIS RECOMMENDED OPERATING PRESSURE.

SAFETY INSTRUCTIONS

SAFETY FIRST

These safety instructions provide information necessary for safe operation of Paslode® tools. **DO NOT ATTEMPT TO OPERATE THE TOOL UNTIL YOU READ AND UNDERSTAND ALL SAFETY PRECAUTIONS AND MANUAL INSTRUCTIONS.**



WEAR EYE AND HEARING PROTECTION

Always wear hearing and eye protection devices, including side shields, when operating or working in the vicinity of a tool.

THE TOOL MUST BE USED ONLY FOR THE PURPOSE FOR WHICH IT WAS DESIGNED

Do not throw the tool on the floor, strike the housing in any way or use the tool as a hammer to knock material into place.

NEVER ENGAGE IN HORSEPLAY WITH THE TOOL

The tool is not a toy so do not use it like one. Never engage in horseplay with the tool or point it at yourself or any other person, even if you think it is not loaded.

NEVER ASSUME THE TOOL IS EMPTY

Check the magazine for fasteners that may be left in the tool. Even if you think the tool is empty or disconnected, never point it at anyone or yourself. Unseen fasteners could fire from the tool.

NEVER CLAMP THE TRIGGER IN A LOCKED OR OPERATING POSITION

The trigger of the tool must never be tampered with, disabled or clamped in a locked or operating position since this will cause the tool to drive a fastener any time the work contacting element depressed.

DO NOT LOAD FASTENERS WITH THE AIR LINE CONNECTED, OR WITH THE TOOL TRIGGER OR WORK CONTACTING ELEMENT DEPRESSED

When loading fasteners into the tool be sure you disconnect the air line and that you do not depress the trigger or work contacting element.



OPERATE THE TOOL ONLY ON A WORKPIECE

The tool should be operated only when it is in contact with the workpiece. Even then you should be careful when fastening thin material or working near the edges and corners of the workpiece since the fasteners may drive through or away from the workpiece.

DO NOT DISABLE OR REMOVE THE WORK CONTACTING ELEMENT

This tool is equipped with a safety mechanism, called a work contacting element, to help prevent accidental firing. Never tamper with, disable or remove the work contacting element. Do not use the tool unless the work contacting element is working properly. The tool could fire unexpectedly.



CARRY THE TOOL ONLY BY THE HANDLE

Always carry the tool by the handle only. Never carry the tool by the air hose or with the trigger depressed since you could drive a fastener unintentionally and injure yourself or someone else.

DO NOT WEAKEN THE TOOL HOUSING

The tool housing is a pressure vessel and should never be weakened by having your company's name, area of work or anything else stamped or engraved into its surface.

DISCONNECT THE TOOL WHEN PERFORMING REPAIRS AND CLEARING JAMS

Never attempt to clear a jam or repair a tool unless you have disconnected the tool from the air line and removed all remaining fasteners from the tool.

ALWAYS USE THE PROPER FITTING FOR THE TOOL

Only MALE pneumatic type air connectors should be fitted to the tool, so that high pressure air in the tool is vented to atmosphere as soon as the air line is disconnected.

NEVER install FEMALE quick disconnect couplings on the tool. Female couplings will trap high pressure air in the tool when the air line is disconnected, leaving the tool charged and able to drive at least one fastener.

DO NOT EXCEED THE MAXIMUM RECOMMENDED AIR PRESSURE



Operate the tool only at the recommended air pressure. Do not exceed the maximum air pressure marked on the tool. Be sure the air pressure gauge is operating properly and check it at least twice a day.

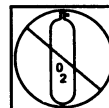

Never use any bottled air or gases such as oxygen to operate the tool since they could cause the tool to explode.

KEEP THE TOOL CLEAN AND LUBRICATED

Clean the tool at least daily and lubricate as required. Never operate a dirty or malfunctioning tool.

USE ONLY PASLODE RECOMMENDED PARTS AND FASTENERS

Use only parts and fasteners specifically designed and recommended by Paslode for use in the tool and for work to be done. Using unauthorized parts and fasteners or modifying the tool in any way creates dangerous situations. Replace all missing warning labels---refer to tool schematic for correct placement and part number.

DANGER

Failure to follow any of the above instructions could result in severe personal injury to tool user and bystanders or cause damage to tool and property.

Contact your local Paslode Representative for presentation of Paslode's Safety Awareness Program

INSTRUCTIONS FOR LOADING

Step No. 1 – Grasp the finish nailer firmly with one hand and press the latch towards the handle with your other hand. Now pull the magazine back towards you

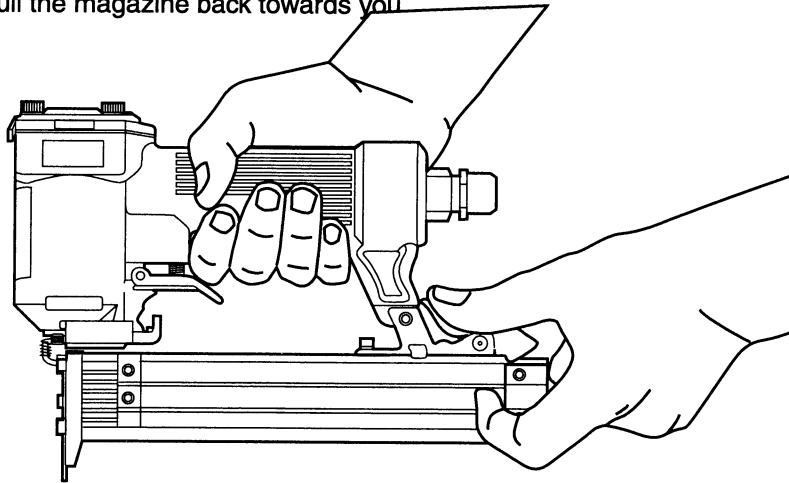

Step No. 2 – Insert the strip with the point of the fastener facing down towards the bottom of the magazine.

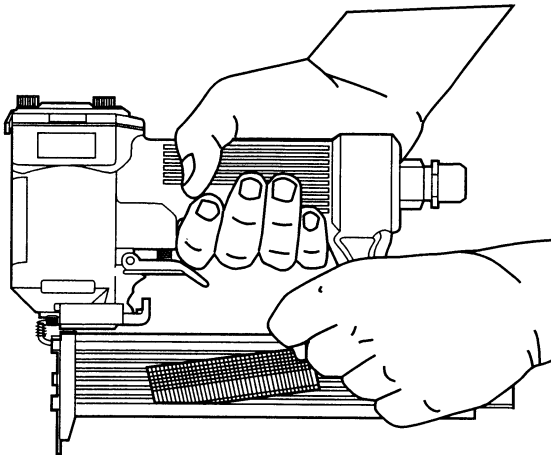

Step No. 3 – Push the magazine firmly towards the front of the tool until it locks in place. The tool is now ready for use.

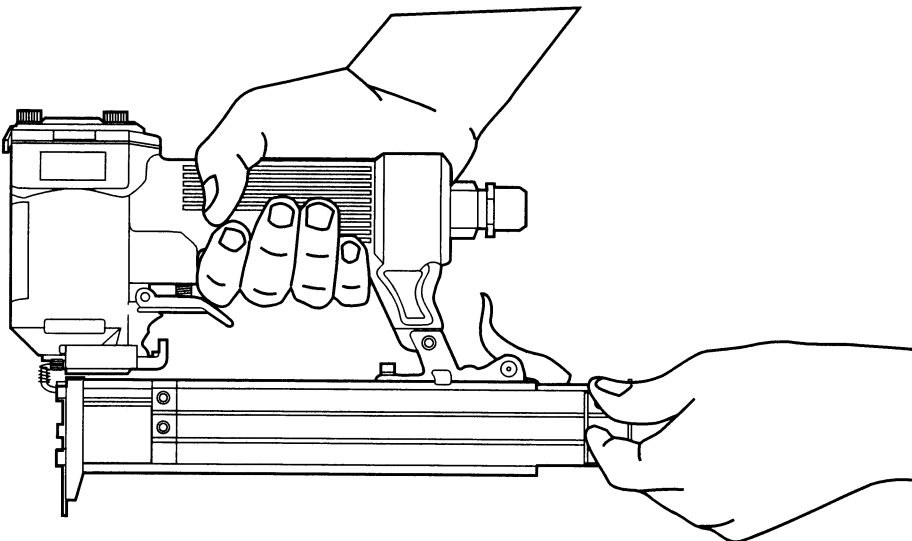

PARTS LEGEND

2125-F18, 590000

1	590001	6	Screw	28	590035	1	Spring Holder
2	590002	7	Washer	29	590036	1	Compression Spring
3	590003	1	Exhaust Cover	30	590037	1	Work Contacting Element
4	590004	1	Compression Spring	→ 31	500536	1	Back Plate
5	590005	1	Seal	▲ 32	590039	2	Screw M4 x 18
6	590006	1	Cap	33	590040	1	Spacer
* 7	590007	1	O-Ring	34	590041	1	Cover
* 8	590022	1	O-Ring	35	590042	9	Washer
9	590008	1	Washer	▲ 36	590043	8	Screw
10	590009	1	Main Valve Piston	37	590070	1	Piston Assembly
*11	590010	1	O-Ring	38	590050	1	Hex Nut M5
*12	590011	1	O-Ring	39	590071	1	Latch Assembly
13	590013	1	Collar	40	590055	1	Screw M5 x 20
14	590014	1	Cylinder	→ 41	500537	1	Fixed Magazine
15	590015	1	Bumper	43	590058	1	Compression Spring
*16	590016	1	O-Ring	→ 44	500538	1	Movable Magazine
17	590023	1	Pipe Assembly	45	590060	1	End Plate
18	590018	1	Housing	→ 46	500539	1	Follower
19	590019	1	Driver Blade Seal	47	590062	1	Spring Holder
20	590020	1	Seal	48	590063	1	Stopper
21	590069	1	Trigger Valve Assembly	49	590064	1	Front Stopper
22	590027	1	Compression Spring	50	590065	1	Screw M4 x 12
23	590028	1	E-Ring	→ 51	401510	1	O-Ring, Piston
24	590029	1	Trigger	** 52	590243	1	Nameplate
25	590030	1	Step Pin	53	590244	1	Warning Label
26	590033	1	Air Plug	54	405477	2	Housing Label
27	590034	1	Support				

* Denotes Normal Wear Items.

** Make sure Warning Label (590244) is properly affixed.
Replace if necessary.

Label available at no charge through the Service Parts Dept.

▲ Apply Loctite 242 (Blue) Part No. 093500.

SAFETY INSTRUCTIONS

WEAR EYE AND HEARING PROTECTION



Always wear hearing protection and eye protection devices, including side shields when operating or working in the vicinity of a tool.



DO NOT EXCEED MAXIMUM
RECOMMENDED AIR PRESSURE

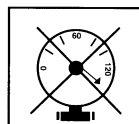

Operate the tool using only the recommended air pressure. Do not exceed the maximum air pressure marked on the tool. Be sure the air pressure gauge is operating properly and check it at least twice a day.

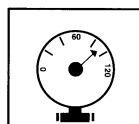

Never use any bottled air or gases such as oxygen to operate the tool since they could cause the tool to explode.

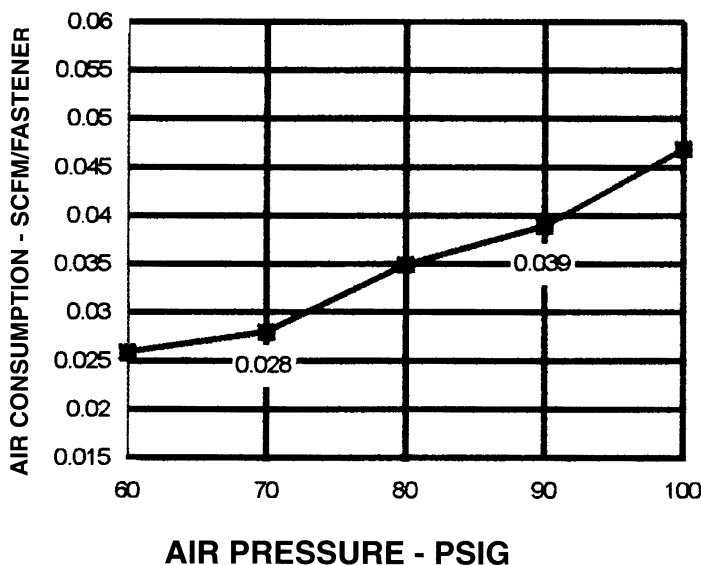

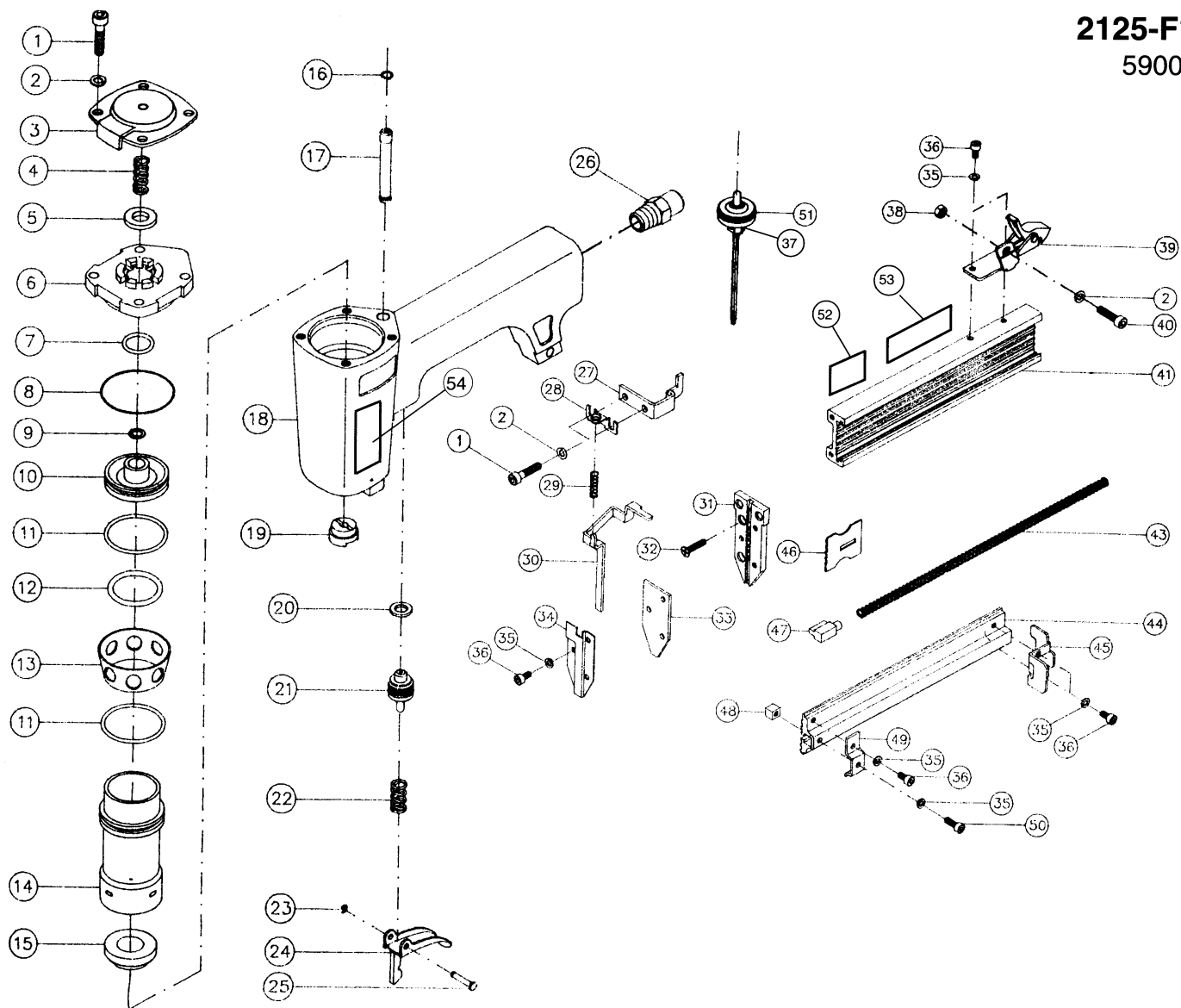

⚠ WARNING

All parts must be periodically inspected and replaced if worn or broken. Failure to do this can affect the tool's operation and present a safety hazard.

ACCESSORIES

Safety Glasses

Clear
Tinted

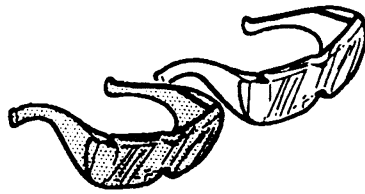

Part No. 402510

Part No. 402512

Lubricants and Loctite

Loctite 242 (Blue)
Lubricating Oil
Lubricating Oil with Anitfreeze
Chemplex 710 Lubricant 1lb.

Part No. 093500

Part No. 219026

Part No. 219090

Part No. 403734

Degreaser Cleaner

Ideal cleaner for all Paslode tools.

Part No. 219086



An Illinois Tool Works Company
888 Forest Edge Drive
Vernon Hills, Illinois 60061-3105